



HAL
open science

Off-line PWM control with a three phases relaxed symmetry applied to a two-level inverter

Adrien Bourgeade, Malek Ghanes, Maurice Fadel, Abdelkader Bouarfa,
Jean-Pierre Barbot

► **To cite this version:**

Adrien Bourgeade, Malek Ghanes, Maurice Fadel, Abdelkader Bouarfa, Jean-Pierre Barbot. Off-line PWM control with a three phases relaxed symmetry applied to a two-level inverter. 2021 IEEE Conference on Control Technology and Applications (CCTA), Aug 2021, San Diego, United States. pp.595-600, 10.1109/CCTA48906.2021.9659137 . hal-03557703

HAL Id: hal-03557703

<https://ut3-toulouseinp.hal.science/hal-03557703>

Submitted on 4 Feb 2022

HAL is a multi-disciplinary open access archive for the deposit and dissemination of scientific research documents, whether they are published or not. The documents may come from teaching and research institutions in France or abroad, or from public or private research centers.

L'archive ouverte pluridisciplinaire **HAL**, est destinée au dépôt et à la diffusion de documents scientifiques de niveau recherche, publiés ou non, émanant des établissements d'enseignement et de recherche français ou étrangers, des laboratoires publics ou privés.

Off-line PWM control with a three phases relaxed symmetry applied to a two-level inverter

Bourgeade Adrien¹, Malek Ghanes¹, Fadel Maurice², Bouarfa Abdelkader³, Barbot Jean-Pierre⁴

Abstract—To control static converters, several Pulse Width Modulation (PWM) was proposed. Their aim was to achieve a specific minimisation by choosing the inverter switching angles. Optimal pulse patterns could be obtained considering classic symmetries on a single leg. Also known as Quarter Wave Symmetry (QWS), Half Wave Symmetry or Full Wave Symmetry (FWS). By this way the angles on each leg can be easily deduced from the solution of the first leg, it is also known that the harmonics multiple of three are systematically removed. In this work, any symmetry is considered and simulation results are provided according to this new strategy based on relaxation symmetry. Evaluation is done with four objectives functions Weighted Total Harmonic Distortion (WTHD) and three types of electric motor models. According to the models, the new strategy is compared to the case where the symmetries (QWS, HWS and FWS) are considered. In the motor models is computed efficiency, which includes switching and conduction losses inside the legs of the inverter. Models and methods was evaluated in simulation with arbitrary parameters.

Index Terms—PWM, Optimised pulse patterns, Three-phase symmetry relaxation, off-line optimisation.

I. INTRODUCTION

In order to change the AC power of an electrical motor allowing to control the motor, an inverter is needed. It will transform the tension of the battery (continuous) to a tension which can be used by a motor (three alternative phases). In an automotive context, there are many problems which have to be considered, the first one is a cost problem. This problem leads us to consider a minimum of switches. In this paper it is considered here an inverter with only six switches composed each of an IGBT with an anti-parallel diode. This inverter is then composed of three legs and is commanded by two levels of tension.

Carrier based PWM exists since years to control power electronic devices such as inverters. Many works tried to improve the PWM by injecting harmonics in the modulated signal [1]–[5], or on searching vector modulation methods [6], [7].

The gold standard of PWM strategies is the Space Vector Modulation (SVM), indeed it demonstrated an important efficiency in comparison with the Sinusoidal PWM (SPWM).

¹Ecole Centrale de Nantes, LS2N UMR CNRS 6004, Nantes, France
adrien.bourgeade@ec-nantes.fr
malek.ghanes@ec-nantes.fr

²ENSEEIH, LAPLACE UMR CNRS 5213, Toulouse, France
maurice.fadel@laplace.univ-tlse.fr

³Renault Group, Technocentre, 1 Avenue du Golf, 78280 Guyancourt, France
abdelkader.bouarfa@renault.com

⁴Quartz EA7393 and LS2N UMR CNRS 6004, Cergy-Pontoise, France
barbot@ensea.fr

This work was supported by the project Chair between Renault and Centrale Nantes about performances of electric vehicles propulsion.

SVM also allows an extension of the linear zone, this effect have a positive influence on Total Harmonic Distortion (THD) [2], [3]. SVM strategy is often used to command inverter connected with motors thanks to its vector representation. It has been also shown that SVM strategy can be replaced by a zero sequence component injection [3], [6], [7]. Thanks to this method SVM strategy can be understood as a carrier based strategy.

More recently a new class of PWM (off-line) appeared with technical progress (Micro-controllers) [8]–[13]. Off-line PWM are also called Optimal Pulse Patterns (OPP).

The computation based on a mathematical model for OPPs is the most common way to compute solutions [8], [9], [14]–[19]. These papers are concerned about minimisation of THD or WTHD with different algorithms because it is very simple to compute, and, furthermore WTHD is a good way to evaluate current behaviour in an motor without considering motor parameters.

One of the main advantages of off-line solutions, is their linear zone extended to the modulation index $m_{\max} = \frac{2}{\pi}$, [3]. This way all the off-line strategies should be better than the SVM one.

In [8], [11], they evaluate respectively OPP for WTHD and salient pole synchronous machine. Their approach is based on harmonic evaluation.

Other people worked on the Selective Harmonic Elimination PWM (SHEPWM). The principle is to select precise harmonics to eliminate and then trying to eliminate them, [10], [19], [20]. This objective is the second most classic objective function with WTHD. SHEPWM is not considered here, because it seems to be a particular case of WTHD, furthermore, choosing among all the harmonics which one to eliminate in order to reduce engine losses is quite complex.

The work presented here do a study on off-line PWM modulation, these solutions will be used in a control loop to feed a synchronous motor in an electric vehicle for our industrial partner. The control loop is considered here as a black box sending correct information about signal frequency (f_1) and desired tension ($m.E_{DC}$, here m is called modulation index and E_{DC} the bus tension). For now this study is only based on simulations consisting a first step to evaluate PWM strategies but not ideal. This decision was taken to have as quick as possible a first good approximation of what expected with a real motor. The purpose of this paper is to propose a complete and directly applicable optimisation problem, and a PWM strategy comparison between the proposed solution without symmetry and a classical symmetry FWS. FWS has

demonstrated in [9] its superiority in front of SVM, QWS and HWS.

In the rest of the paper, a recall about mathematical modelling of objective functions is done in section II. The new method is then presented on section III. Section IV is reserved for the computation method of solutions. Section V, a discussion of the results obtained with models of section II is done. In conclusion some perspectives of improvements are given.

II. OBJECTIVE FUNCTION DESCRIPTION

To evaluate correctly the losses inside the inverter and the motor, it is necessary to consider the motor in order to do computations. Nevertheless the solutions found can be used for many applications, and many kind of loads, which involves an inverter. The computation method, is here applied in an automotive context but can be transposed to any another problem. The automotive context was chosen because of our industrial partner.

The motor model will be used for two purposes. The first one is to do the optimal computation. That mean that the computation must be as quick as possible. But, on another hand, it is necessary to have a reliable model to be very precise on the expected results on a real motor.

Four types of models are considered in this study. They are the WTHD and three other models of motor, one called RL, another RLE, and a dq motor model. The RL one is not really a classical motor model. But it's main advantage is its simplicity. The two last motors are more complicated, and even if they are not perfect, they afford a good approximation of solutions quality. In all the following models R , represent a resistance, L an inductance and ω a pulsation with $\omega = 2\pi f_1$.

Let's consider an ideal model of an inverter as (1), also see Fig. 1 for the associate electric diagram [3].

$$\begin{bmatrix} V_{an} \\ V_{bn} \\ V_{cn} \end{bmatrix} = \frac{E_{DC}}{3} \begin{bmatrix} 2 & -1 & -1 \\ -1 & 2 & -1 \\ -1 & -1 & 2 \end{bmatrix} \cdot \begin{bmatrix} S_a \\ S_b \\ S_c \end{bmatrix} \quad (1)$$

E_{DC} is the bus tension, S_x is the command of the leg x and V_{xn} is the simple tension in the leg x of the motor.

A. WTHD

A lot of studies worked with the WTHD, because of its motor parameters dependency furthermore it allow to evaluate the quality of the solutions really fast and easily. The WTHD equation is represented as 2 [3].

$$V_{WTHD,\%} = \frac{100}{V_1} \sqrt{\sum_{n \geq 2} \left(\frac{V_n}{n} \right)^2} \quad (2)$$

V_1 is the desired tension, which is also the fundamental tension and V_n is the tension of n^{th} harmonic.

In order to implement it in a solver, a modified WTHD is computed (3). This equation do not have any physic meaning

but is useful to study the solutions.

$$V_{WTHDm} = \sqrt{\sum_{n \geq 2} \frac{a_{n,V}^2 + b_{n,V}^2}{n^2}} \quad (3)$$

$a_{n,V}$ and $b_{n,V}$ are the Fourier coefficients of the n^{th} harmonic tension.

B. The RL and RLE model

First of all, the following models are not exacts, and do not fit to usual motor models. The purpose of these models is to compare them with a real engine (dq model here). The objective is to choose the model, which, with the optimisation afford the best dq results. In another words, RL model is only useful in our optimisation context. If the motor is represented only with a resistance and an inductance, the current equation will be described by (4). With the knowledge of this current the losses insides the switches can be computed, indeed switches losses are linked to current value.

$$i(\alpha) = \left(i_0 - E_{DC} \sum_{n \geq 1} \frac{Ra_n - nL\omega b_n}{(nL\omega)^2 + R^2} \right) e^{-\frac{R\alpha}{L\omega}} + E_{DC} \sum_{n \geq 1} \frac{(Ra_n - nL\omega b_n) \cos(n\alpha)}{(nL\omega)^2 + R^2} + E_{DC} \sum_{n \geq 1} \frac{(Rb_n + nL\omega a_n) \sin(n\alpha)}{(nL\omega)^2 + R^2} \quad (4)$$

On (4), a transient period term is observed and has inside it a $e^{-\frac{R\alpha}{L\omega}}$, which depend of the electric angle, that mean that it also depend of time. Let's observe that $\lim_{\alpha \rightarrow \infty} e^{-\frac{R\alpha}{L\omega}} = 0$. In section IV optimisation computation is done without transient period.

The steady state term is identified in the second part of the equation (4). Extraction of current Fourier coefficients is then done in (5).

$$\begin{cases} a_{n,I} = E_{DC} \frac{Ra_n - nL\omega b_n}{(nL\omega)^2 + R^2} \\ b_{n,I} = E_{DC} \frac{Rb_n + nL\omega a_n}{(nL\omega)^2 + R^2} \end{cases} \quad (5)$$

To compute the RLE model an Electromotive force is added. This force will react as a voltage source inside the legs of the RL device (see figure 1). This figure represent one of the most basic motor model, which is very useful for people that work in command control to develop a quick start controller for the motor. The main problem related to this model, that it is not precise enough to represent correctly a salient electric motor. With this model the equations (4) is modified to give us (6)

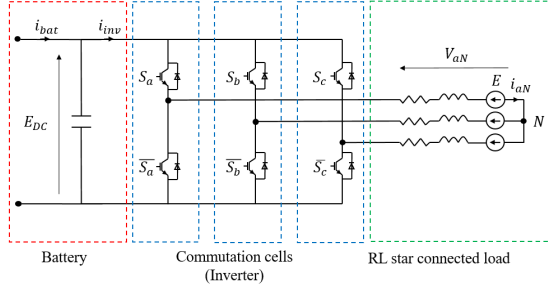

Fig. 1. Scheme of the RLE model

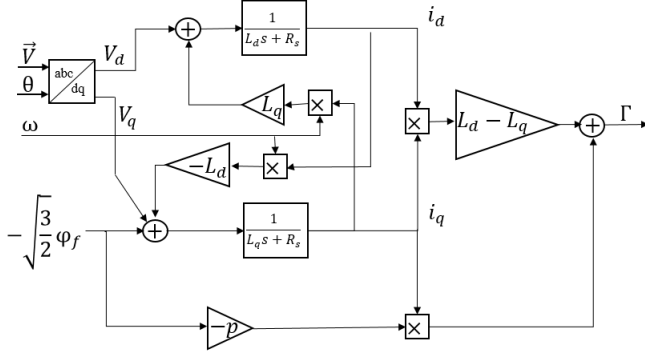

Fig. 2. Scheme of the dq motor model

$$i(\alpha) = \left(i_0 + \frac{E(\omega)}{R} - E_{DC} \sum_{n \geq 1} \frac{Ra_n - nL\omega b_n}{(nL\omega)^2 + R^2} \right) e^{-\frac{R\alpha}{L\omega}} + E_{DC} \sum_{n \geq 1} \frac{(Ra_n - nL\omega b_n) \cos(n\alpha)}{(nL\omega)^2 + R^2} + E_{DC} \sum_{n \geq 1} \frac{(Rb_n + nL\omega a_n) \sin(n\alpha)}{(nL\omega)^2 + R^2} - \frac{E(\omega)}{R} \quad (6)$$

let's remark that the Electromotive force vary depending on the motor speed, and is not explicit here.

C. The dq model

The dq model 2 need more computation time than the previous ones because of numerical differential resolution. Then, if that equation does not afford enough advantages, more simple models will be preferred. Fig. 2 can be also written with differential equations (7) and (8).

$$\frac{di_d}{dt} = \frac{V_d}{L_d} + \frac{L_q}{L_d} \omega i_q - \frac{R_s}{L_d} i_d \quad (7)$$

$$\frac{di_q}{dt} = \frac{V_q}{L_q} - \frac{L_d}{L_q} \omega i_d - \frac{R_s}{L_q} i_q - \sqrt{\frac{3}{2}} \frac{\omega \phi_f}{L_q} \quad (8)$$

With these equations, like for models presented in section II-B, a current equation is established 9 [21]. Current which is useful to compute the losses inside the inverter as seen in

section II-D.

$$i_{abc} = \sqrt{\frac{2}{3}} \begin{bmatrix} \cos(\theta) & -\sin(\theta) \\ \cos(\theta - \frac{2\pi}{3}) & -\sin(\theta - \frac{2\pi}{3}) \\ \cos(\theta + \frac{2\pi}{3}) & -\sin(\theta + \frac{2\pi}{3}) \end{bmatrix} \begin{bmatrix} i_d \\ i_q \end{bmatrix} \quad (9)$$

With $\theta = \omega t$ and homopolar current is equal to zero ($i_h = 0$) because of the balanced motor .

D. Losses in the inverter

In (1), the inverter is supposed perfect. But it exists losses inside this power device. The main losses in the inverter are due to IGBT and diode losses. There is two kind of losses, the conduction losses (10) and the switching losses (11). The first one is due to the internal resistance of the semiconductors. The second one, is due to the current discontinuities.

$$\mathcal{P}_{cond} = \frac{1}{2\pi} \int_0^{2\pi} u(\alpha) V_{ce} |i(\alpha)| d\alpha \quad (10)$$

$$\mathcal{P}_{sw} = \frac{1}{2} f_1 \sum_{i=1}^{N_{dec}} (E_{on}(\alpha_i) + E_{off}(\alpha_i)) + \frac{1}{2} f_1 \sum_{i=1}^{N_{dec}} [(-1)^i (E_{on}(\alpha_i) - E_{off}(\alpha_i))] \quad (11)$$

Equations (10) and (11) [5] are quite simple. Indeed they depend on few parameters and on the angle position. The sub functions V_{ce} , E_{on} and E_{off} are given by the data sheets of the chosen semiconductors. u is equal to one when the switch let the current go through the semiconductor and zero otherwise. u depends on the OPP found, it is the same for i (current) computed in previous sections for the different models. Finally because E_{on} and E_{off} depend on the current when the switch will be opened or closed. So E_{on} and E_{off} also depend on the OPP found by the algorithm. To simplify the computation, IGBT and diode are assumed to have the same characteristics.

E. Efficiency computation

To compute the efficiency, two information are needed. The first one is the useful power, and the second one are the losses. For the useful power, it depends on the motor model. About the losses a sum of the spoiled power and the inverter losses computed in section II-D is performed. The complete expression of the computation is then accessible with (12), (13) and (14). η symbol designate an efficiency.

$$\eta_{RL} = \frac{3V_1 I_1 \cos(\phi_1)}{3\mathcal{P}_{cond} + 3\mathcal{P}_{sw} + 3 \sum_{n \geq 1} (V_n I_n \cos(\phi_n))} \quad (12)$$

$$\eta_{RLE} = \frac{3E(\omega) \cdot I}{3\mathcal{P}_{cond} + 3\mathcal{P}_{sw} + 3 \sum_{n \geq 1} (V_n I_n \cos(\phi_n))} \quad (13)$$

$$\eta_{dq} = \frac{\Gamma \Omega}{3\mathcal{P}_{cond} + 3\mathcal{P}_{sw} + 3 \sum_{n \geq 1} (V_n I_n \cos(\phi_n))} \quad (14)$$

Here Γ represent the torque of the motor in $N.m$ and Ω the motor speed in $rad.s^{-1}$

III. NEW OPTIMISATION PROBLEM SETTING

The new method purpose is to do the hypothesis that the symmetry between phases do not exist anymore, but will be forced by constraints in the optimisation problem. With this new hypothesis, the optimisation problem is now written like (15). The idea, here is to find the optimal pulse pattern, according to the chosen objective function ((3), (12) or (13)). This relaxation of the assumptions will increase the quality of the solutions. Indeed feeding this optimisation problem with a FWS solution as starting point, will ensure that the solution will be better than the FWS one. In the worst case the solution quality will be the same than the FWS one.

A. Angle optimisation problem setting

$$\left\{ \begin{array}{l} f.o \quad \min(f(\mathbf{x})) \\ s.c \quad \mathbf{x} = [\mathbf{x}_a; \mathbf{x}_b; \mathbf{x}_c] \\ \quad x_{a,k} \leq x_{a,k+1} + dx_{min} \\ \quad x_{b,k} \leq x_{b,k+1} + dx_{min} \\ \quad x_{c,k} \leq x_{c,k+1} + dx_{min} \\ \quad x_{a,4N+2} \leq u_b, \quad x_{b,4N+2} \leq u_b, \quad x_{c,4N+2} \leq u_b \\ \quad x_{a,1} \geq l_b, \quad x_{b,1} \geq l_b, \quad x_{c,1} \geq l_b \\ \quad a_{0,a} = 0, \quad a_{0,b} = 0, \quad a_{0,c} = 0 \\ \quad a_{1,a} = 0, \quad a_{1,b} = -\frac{\sqrt{3}}{2}m, \quad a_{1,c} = \frac{\sqrt{3}}{2}m \\ \quad b_{1,a} = m, \quad b_{1,b} = -\frac{1}{2}m, \quad b_{1,c} = -\frac{1}{2}m \end{array} \right. \quad (15)$$

With $\forall k \in \llbracket 1; 4N + 2 \rrbracket$. In problem (15), f designates the chosen objective function ((3), (12) or (13)), and N the number of switches per quarter period. Constraints, are designed to respect three conditions. Time between switching times cannot be lower to dx_{min} . Switching angles are bounded on a period (TABLE I) and finally, all the tensions must respect the correct tension with a correct initial phase for the fundamental.

To analyse the new method command, the same equation than for the FWS given by [8] is used. They are the same equations except that the angle index number vary between 1 and $4N + 2$. The main difference is that here the symmetry between the phases does not exist, then no harmonics will be forced to be equal to zero. In the problem (15), k is inside 1 and $4N + 2$. So it could appears there is one more switching in comparison than FWS and 2 more switching in comparison with QWS and HWS. But, The first additional switching is due to the symmetry which requires to have a switching in π . The second additional switching is due to the 2π symmetry, that add a switching at the end of the period.

TABLE I: Optimisation parameters for (15)

symmetries/parameters	l_b	u_b
New method	dx_{min}	$2\pi - dx_{min}$

IV. PROPOSED RESOLUTION

In order to compute the solutions, fmincon function from MatLab is used. Because the space of work is full of local minimum, a good starting point have to be chosen. Some random initial points are created. Then a quality evaluation of

each point is performed with (16). This equation consider the current value of the objective function which is modified, according to the respect of constraints with penalty coefficients. This way a good starting point will be selected, a starting point which have a good fitness and violate a minimum of constraints.

$$f_v = f(\mathbf{x}) + K_1 \sum_i (\max(c_i, 0)) + K_2 \sum_i g_i \quad (16)$$

In (16), inspired by the work presented in [22], f_v represents the current objective value with constraint penalties. f , is the objective function (see II for more details). \mathbf{x} the solution to test. K_1 and K_2 are two penalty constants to choose (for example $K_1 = K_2 = 10^6$). \mathbf{c} is the vector of constraints, defined as lower than zero if the constraint is respected and greater than zero if the constraint is violated. In (16), g_i is defined as follow:

$$g_i = \begin{cases} 1 & \text{if } c_i > 0 \\ 0 & \text{otherwise} \end{cases} \quad \forall i \quad (17)$$

The first penalty of (16) indicates how far away the current solution is from the feasible domain and the second penalty indicates how many constraints are violated.

After application of the equation (16), to a large quantity of points and selection of the best fitness point. fmincon try to solve the problem (15), from the point found previously. Furthermore, in order to keep the solution quality, computation with fmincon is done to two other starting points. The first starting point is found by doing an extension of the previous symmetry. In another words an extension of QWS is done to compute the HWS (equation (18)), the HWS to compute FWS (equation (19)) and FWS to compute solutions without symmetry (equation (20)).

$$\mathbf{x}_H = [x_{Q,1}, \dots, x_{Q,N}, \pi - x_{Q,N}, \dots, \pi - x_{Q,1}] \quad (18)$$

$$\mathbf{x}_F = [x_{H,1}, \dots, x_{Q,2N}, \pi, \pi + x_{H,1}, \dots, \pi + x_{H,2N}] \quad (19)$$

$$\mathbf{x}_{tot} = \begin{cases} \mathbf{x}_F \\ \text{sort}((\mathbf{x}_F - \frac{2\pi}{3}) \bmod 2\pi) \\ \text{sort}((\mathbf{x}_F - \frac{4\pi}{3}) \bmod 2\pi) \end{cases} \quad (20)$$

The second point chosen is the solution for the previous modulation index. This way the solution when $m = 0.5$, will be one of the starting point of the computation $m = 0.501$. This way, the previous local minimum is conserved.

The method has been evaluated on a very simplified motor of four poles pair.

V. SIMULATION RESULTS AND DISCUSSION

A. Results

In the Fig. 3, the WTHD value computed with the WHD objective function (2) is shown for two strategies, the FWS and the new method. The switching frequency is set at $f_s = 2f_1$, in another words $N = 2$ (N is the number of commutations per quarter period). In the same way, Fig. 4 was computed with the RL objective function (12) and Fig. 5 with the RLE (13) one. Here only the results for $N = 2$

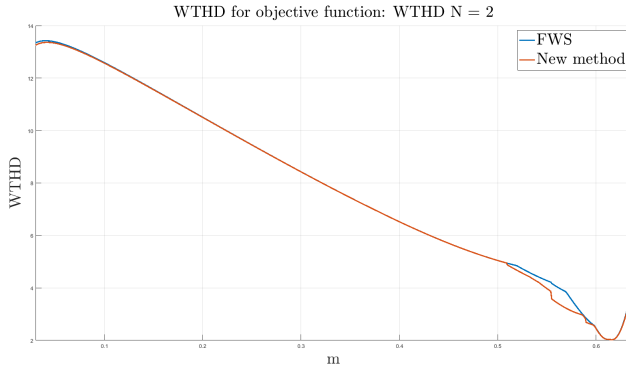

Fig. 3. Comparison between FWS and relaxed method according to WTHD for $N = 2$ when the objective function is WTHD

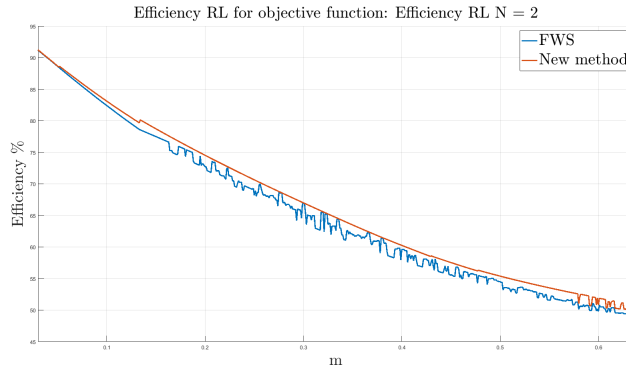

Fig. 4. Comparison between FWS and relaxed method according to RL efficiency for $N = 2$ when the objective function is the RL model

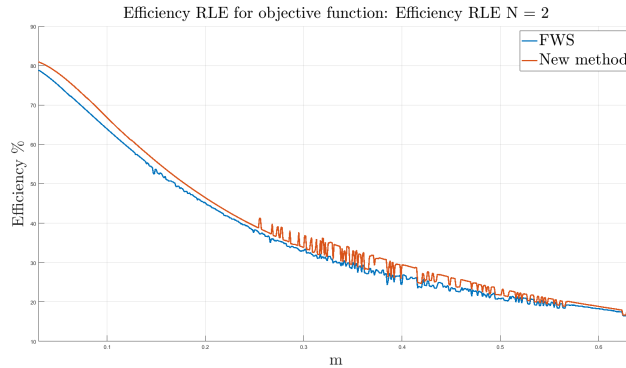

Fig. 5. Comparison between FWS and relaxed method according to RLE efficiency for $N = 2$ when the objective function is the RLE model

TABLE II: Comparison between solutions: mean value of the solutions for two different N

f.o	f	$\bar{m}_{F,2}$	$\bar{m}_{T,2}$	$\bar{m}_{F,5}$	$\bar{m}_{T,5}$
WTHD	WTHD	8.1	8.1	4.2	4.2
	η_{dq}	19.8	19.8	19.2	19.5
η_{RL}	η_{RL}	66.5	67.67	61.3	61.9
	η_{dq}	19.3	18.9	19.4	19.3
η_{RLE}	η_{RLE}	38.3	40.0	31.7	34.9
	η_{dq}	19.4	20.26	19.2	20.1

are represented for readability. But results have been found for $N = 2$ to $N = 5$.

On each curve and for the computed objective function our method is at least as good as FWS. This way the proposed strategy is shown to be the best way to compute the commutation angle in the considered symmetries. Nevertheless, the advantage is often small. For the WTHD objective function, the gain is visible only when m is high enough Fig. 3.

On TABLE II and TABLE III, different results from a specific objective function are represented. For each a computation of the related function and the dq efficiency was performed. The second one is useful in order to determine which model is the most accurate with the dq model. Indeed dq model is supposed to have the most accurate behaviour of a real motor. To do this comparison between the dq model motor and the other models, the mean value for the FWS and $N = 2$ ($\bar{m}_{F,2}$) (TABLE II), but also for $N = 5$ ($\bar{m}_{F,5}$) is computed. The same thing was done for the proposed strategy ($\bar{m}_{T,2}$ and $\bar{m}_{T,5}$). In another hand maximal gain for the considered objective function is computed, called Δ (TABLE III).

This way a mean gain of 0.05% for the WTHD is observed, 0.89% for the RL model and 2.45% for the RLE one.

About the potential punctual gain it can reach 0.2% for the WTHD, more than 14% for the RL model, and 13.5% for the RLE one.

TABLE III: Comparison between solutions: Maximum gap between our method and FWS for two different N

f.o	f	Δ_2	Δ_5
WTHD	WTHD	0.1	0.2
	η_{dq}	2.2	1.3
η_{RL}	η_{RL}	3.3	14.7
	η_{dq}	6.8	2.0
η_{RLE}	η_{RLE}	5.0	13.59
	η_{dq}	2.7	5.1

According to the highest mean of dq efficiency, it appears that the RLE model is the most accurate one.

The efficiency computed with equation (14) is not regular with the other objective functions. Finding a simple model is really important, because computation of the solutions with the dq objective function was not successful because of the computation time. Computation time is one of the reason of why the only considered electrical frequency was 50Hz, which is equivalent to 750rpm. The 750rpm motor speed, is an arbitrary parameter, to test the algorithm and method. Increasing this frequency will result in an increasing of the minimal gap angle between the switches, and, as an implication, the solutions will be different.

Here, all the results has been computed with arbitrary parameters then it is necessary to see the shape and not the absolute value of efficiency.

B. Discussion

In this paper a demonstration that the new method used is at least as good as FWS, the superiority of the method is then established. But there is a lot of ignored problems that should be interesting to study. Indeed electromagnetic compatibility (EMC) [23], or noise and harshness [24]–[26] are ignored here but cannot be neglected. Furthermore the behaviour of the OPP found previously while the motor starting (i.e. in transient period) was ignored too. Furthermore these results has been only found in simulation. It also remains to implement these solutions on a real electric motor, which is not easy because the number of switching per quarter period can change every time in order to respect the motor synchronism. This last point is perhaps the major problem of off-line PWM strategies.

The difference between strategies will be perhaps small, and on a real motor, the new strategy gain could be hard to measure because of sensors uncertainties.

VI. CONCLUSION

In this paper a new PWM method with a relaxation of symmetry was proposed. Four objective functions was presented, in order to test the method and compare it with more classical PWM. The simulation results have been obtained with three objective functions among the four defined. For all the computed results, the new strategy afford the best results or at least the same quality than the FWS solution. In next works it will be necessary to implement this strategy on a real motor, in order to confirm the feasibility of the proposed method.

REFERENCES

- [1] J. Holtz. Pulsewidth modulation for electronic power conversion. *Proceedings of the IEEE*, 82(8):1194–1214, 1994.
- [2] J. Holtz. Advanced pwm and predictive control - an overview. *IEEE Transactions On Industrial Electronics*, 63(6):3837–3844, June 2016.
- [3] D.G. Holmes & T.A. Lipo. *Pulse Width Modulation for Power Converters: Principles and Practice*. Wiley-IEEE Press, 2003.
- [4] A. Bouarfa, M. Bodson, and M. Fadel. An optimization formulation of converter control and its general solution for the four-leg two-level inverter. *IEEE Transactions on Control Systems Technology*, 26(5):1901–1908, 2018.
- [5] S.L. Capitaneanu B. de Fornel M. Fadel J. Faucher & A. Almeida. General and algebraic synthesis for pwm methods. *EPE Journal*, 11(3):11–28, 2001.
- [6] A. M. Bozorgi, M. Monfared, and H. R. Mashhadi. Optimum switching pattern of matrix converter space vector modulation. In *2012 2nd International eConference on Computer and Knowledge Engineering (ICCKE)*, pages 89–93, 2012.
- [7] K. Zhou and D. Wang. Relationship between space-vector modulation and three-phase carrier-based pwm: a comprehensive analysis [three-phase inverters]. *IEEE Transactions on Industrial Electronics*, 49(1):186–196, 2002.
- [8] A. Birth T. Geyer H. du Toit Mouton & M. Dorfling. Generalized three-level oprimal pulse patterns with lower harmonic distortion. *IEEE Transactions on Power Electronics*, 2019.
- [9] A. C. Birth. *Model predictive control of a medium-voltage grid-connected convertre with LC filter usinp optimal pulse patterns with relaxed symmetry*. PhD thesis, Stellenbosch University, 2020.
- [10] Dominik Cikač, Nikola Turk, Neven Bulić, and Stefano Barbanti. Pulse pattern optimization based on brute force method for medium-voltage three-level npc converter with active front end. *Electronics*, 9(10), 2020.
- [11] Nina Hartgenbusch, Rik W. De Doncker, and Anna Thünen. Optimized pulse patterns for salient synchronous machines. In *2020 23rd International Conference on Electrical Machines and Systems (ICEMS)*, pages 359–364, 2020.
- [12] R. Fotouhi L. Leitner R. Kennel & H. du Toit Mouton. An efficient method to calculate optimal pulse patterns for medium voltage converters. *978-1-4799-4032-5/14 IEEE*, pages 1221–1226, 2014.
- [13] R. Fotouhi A. Sorokin R. Kennel & H. du Toit Mouton. An efficient method to calculate optimal pulse patterns for multi-level converters. *9th International Conference on Power Electronics-ECCE Asia*, pages 533–539, 2015.
- [14] A.D. Birda J. Reuss & C. Hackl. Synchronous optimal pulse-width modulation with differently modulated waveform symmetry properties for feeding synchronous motor with high magnetic anisotropy. *ReseachGate, Working Copy*, 2017.
- [15] K.L. Shi and H. Li. Optimized random pwm strategy based on genetic algorithms. In *IECON'03. 29th Annual Conference of the IEEE Industrial Electronics Society (IEEE Cat. No.03CH37468)*, volume 1, pages 7–11 vol.1, 2003.
- [16] K.L. Shi & H. Li. Optimized pwm strategy based on genetic algorithms. *IEEE Transactions on industrial electronics*, 52(05):1458–1461, 2005.
- [17] E. Sournac. *Variateur de vitesse pour machine asynchrone Commande numérique et stratégies MLI, Optimisation des Modulations*. PhD thesis, ENSEEIHT, Laboratoire d'Electrotechnique et d'Electronique Industrielle, 1990.
- [18] H. Hosseinnia & D. Nazarpour. Utilization of a novel meta heuristic algorithm to minimize total harmonic distortion. *Majlesi Journal of Electrical Engineering*, 12(3):77–84, September 2018.
- [19] W. Fei X. Ruan & B. Wu. A generalized formulation of quarter-wave symmetry she-pwm problems for multilevel inverters. *IEEE Transactions on Power Electronics*, 24(7):1758–1766, July 2009.
- [20] Y. Sahali & M.K. Fellah. Selective harmonic elimination pulse-width modulation technique (she pwm) applied to three-level inverter / converter. *IEEE*, pages 1112–1117, 2003.
- [21] R. H. Park. Two-reaction theory of synchronous machines generalized method of analysis-part i. *Transactions of the American Institute of Electrical Engineers*, 48(3):716–727, 1929.
- [22] M.R Sierra & C.A.C Coello. Improving pso-based multi-objective optimization using crowding, mutation and ϵ -dominance. *Evolutionary Multi-Criterion Optimization, Third international Conference EMO*, pages 505–519, March 2005.
- [23] P. Lezynski. Random modulation in inverters with respect to electromagnetic compatibility and power quality. *IEEE Journal of Emerging and Selected Topics in Power Electronics*, 6(2):782–790, 2018.
- [24] I. Takahashi and H. Mochikawa. Optimum pwm waveforms of an inverter for decreasing acoustic noise of an induction motor. *IEEE Transactions on Industry Applications*, IA-22(5):828–834, 1986.
- [25] A. Ruiz-Gonzalez M.J. Meco-Gutierrez F. Perez-Hidalgo F. Vargas-Merino & J.R. Heredia-Larrubia. Reducing acoustic noise radiated by inverter-fed induction motors controlled by a new pwm strategy. *IEEE Transactions on Industrial Electronics*, 57(1):228–236, January 2010.
- [26] J.F. Gieras C. Wang & J.C. Lai. *Noise of Polyphase Electric Motors*. CRC Press, 2006.